

TRAFFIC LIGHTS

200mm (red/amber/green) for SAFERAISE.
Model: DTIC-SEM-01-220

- **800 METERS OF VISUAL RANGE**
- **TWO-INPUT DECODER CIRCUIT**
- **WIDE ANGLE OF VIEW**
- **LONG USEFUL LIFE**
- **FAILURE OF A LED DOES NOT AFFECT LUMINOSITY**

TRAFIC LIGHT 200 MM (RED/ AMBER/GREEN) SAFERAISE. MODEL: DTIC-SEM-01-220

TRAFFIC LIGHT IMAGE



 **WARNING**

RISK OF ELECTRIC SHOCK. UNPLUG BEFORE REPAIRING OR INSTALLING PRODUCT.

800 METERS OF VISUAL RANGE

TWO-INPUT DECODER CIRCUIT

WIDE ANGLE OF VIEW

LONG USEFUL LIFE

FAILURE OF A LED DOES NOT AFFECT LUMINOSITY

FEATURES

Size	Item	Color	LED qty	Intensity	Wave length	Power	Working voltage
200mm	DTIC-SEM-01-220	Rojo	90pcs	> 230cd	625±5nm	<8W	12VDC
		Ambar	90pcs	> 230cd	590±5nm	<8W	
		Verde	90pcs	> 300cd	505±5nm	<6W	
Working temperature	-40°C ~ +70°C						
Material case	PC						

INTERNAL CONEXIONS

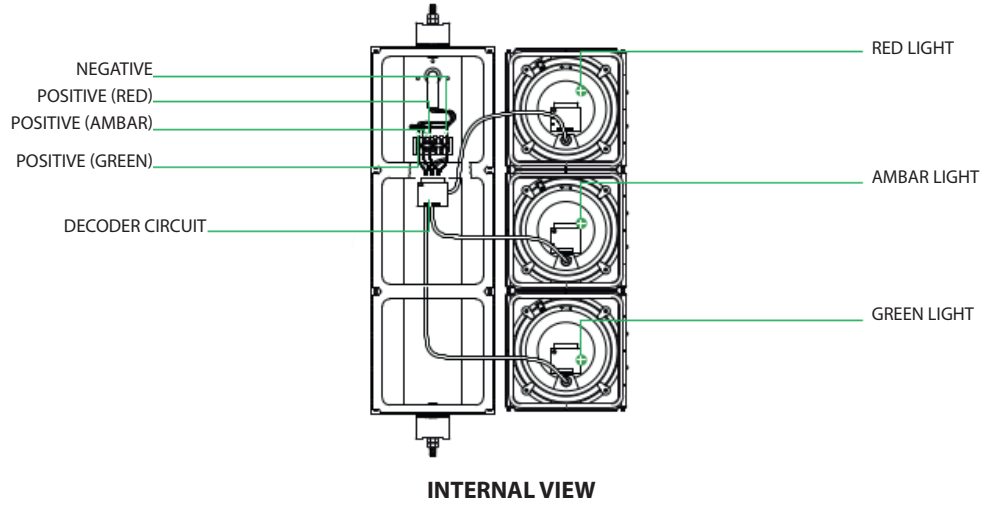

DIMENSIONS

